

# STERLING III

LED Linear

The **Sterling III** LED is a high quality, cost effective linear which realises further power savings over the Sterling II family, without impacting on the luminaire performance.

Featuring a lightweight, single geartray design allows for ease of installation and maintenance, and is available with or without internal opal diffusers to suit any industrial application.



## Mounting Options

Ceiling. Wall. Suspended. Pole.

## Standard Specification

Sterling III LED Linear

Enclosure	GRP with prismatic polycarbonate diffuser and stainless steel retaining clips
Geartray	White coated zintec
Entry	2 x 20mm diameter clearance holes
Termination	4 core 4mm <sup>2</sup> max conductor with through wiring 16A rating
Installation	Two clearance holes for M8 fasteners located on rear of body, sealing washers provided
Control Gear	Electronic Driver
Colour Temperature (CCT)	4000K (Neutral White)
Colour Rendering Index (Ra)	>80
Maintenance	Access via diffuser secured by quick release stainless steel clips
Battery	Internal Ni-Cd (6V) [Emergency version only]
Emergency Duration	3 Hours (03L = 26%; 06L = 14%; 09L = 10%)
Ingress Protection	IP65 to EN 60529
Surge Protection	4kV line to line, 6kV line to earth
Electrical Supply	120-277V AC, 50/60Hz 127-300V DC 220-240V AC, 50/60Hz [Emergency version only]

## Features

- ◆ Highly **Energy Efficient**
- ◆ **Battery management** and automatic self test
- ◆ Lightweight and **slimline construction**
- ◆ **155,000 maintenance free hours** at 45°C (L70)

Std. Cat No.	Delivered Output	Power Consumption	Ambient °C	Weight
ST3I/03L/LE	3592 lm	23W	-20 to +55	2.8kg
ST3I/06L/LE	6241 lm	42W	-20 to +55	4.4kg
ST3I/09L/LE	8798 lm	63W	-20 to +45	5.0kg
ST3I/03L/LE/EM	3592 lm	26W	-20 to +50	3.8kg
ST3I/06L/LE/EM	6241 lm	49W	-20 to +50	5.2kg
ST3I/09L/LE/EM	8798 lm	65W	-20 to +45	5.8kg

Options - Suffix to Catalogue No.

/OD	Internal Opal diffusers (approx. 20% reduction in output)	/NST	Non self test inverter (EM only)
/DM	DALI Dimmable driver	/5K	5000K (Cool White) LED Strips
/5FT	5ft body (09L model only)	/3K	3000K (Warm White) LED Strips

**Accessories** *Accessories should be ordered separately*

	Order Code
Pole mounting bracket assembly (38-42mm diameter poles)	SPOL4-100004
Pole mounting bracket assembly (48-52mm diameter poles)	SPOL4-100005
Pole mounting bracket assembly (58-62mm diameter poles)	SPOL4-100006
Hook type ceiling bracket assembly	S3004-100003
Ceiling bracket assembly	S3004-100001
Flush wall mounting bracket assembly (30° luminaire rotation)	S3004-100004
03L wall mounting outreach bracket (use with SPOL4-100004)	NPRO4-0008
06L/09L wall mounting outreach bracket (use with SPOL4-100004)	NPRO4-0012
Internal Opal Diffuser Strips (03L)	S3004-100005
Internal Opal Diffuser Strips (06L & 09L)	S3004-100006

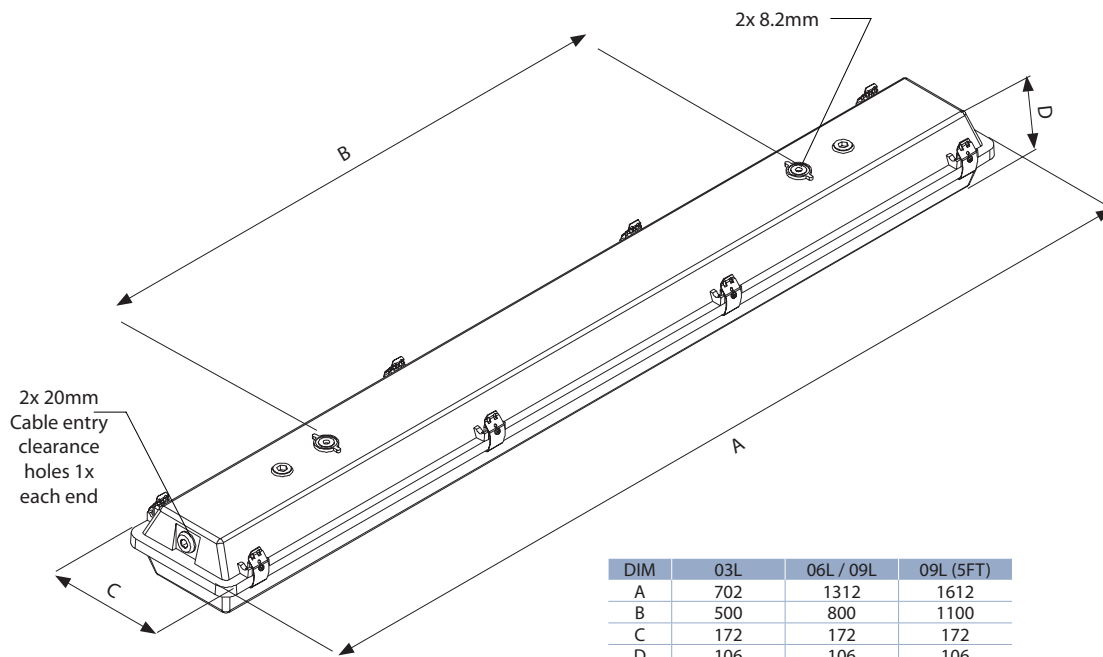

DIM	03L	06L / 09L	09L (5FT)
A	702	1312	1612
B	500	800	1100
C	172	172	172
D	106	106	106